

---

# 7 Modeling Microbial Dynamics under Time-Varying Conditions

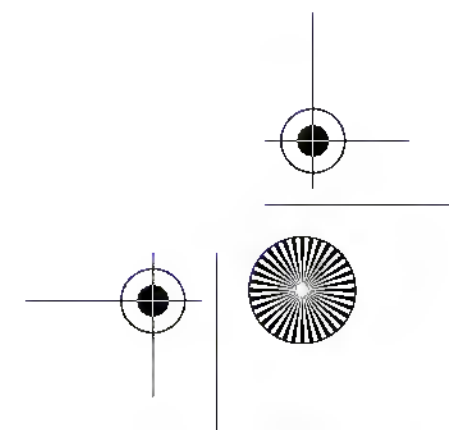
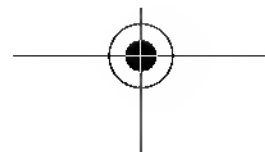
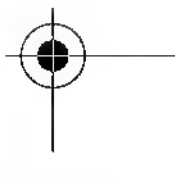
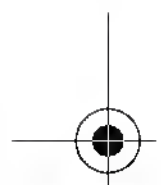
*Kristel Bernaerts, Els Dens, Karen Vereecken,  
Annemie Geeraerd, Frank Devlieghere,  
Johan Debevere, and Jan F. Van Impe*

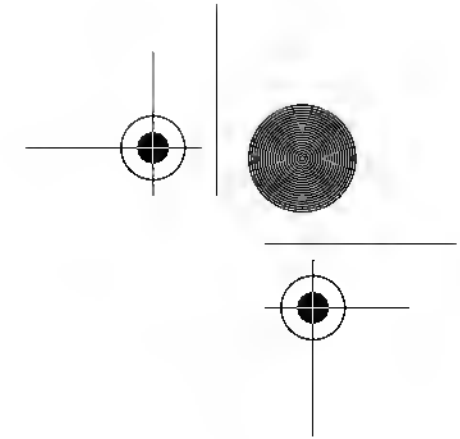
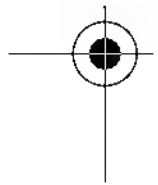
## CONTENTS

- 7.1 Introduction
- 7.2 General Dynamic Modeling Methodology
  - 7.2.1 Basic Elements for Modeling Growth
  - 7.2.2 Basic Elements for Modeling Inactivation
- 7.3 Example I: Individual-Based Modeling of Microbial Lag
  - 7.3.1 Principles of Individual-Based Modeling
  - 7.3.2 Implementation of Mechanistic Insight into an Individual-Based Model
    - 7.3.2.1 Modeling Mechanistic Insight on the Temperature Dependency of Cell Growth
    - 7.3.2.2 Simulation Results
    - 7.3.2.3 Discussion of Results
- 7.4 Example II. Modeling Microbial Interaction with Product Inhibition
  - 7.4.1 Description of the Inhibition Phenomena
  - 7.4.2 Modeling Microbial Growth with Lactic Acid Production and Inhibition
  - 7.4.3 Discussion of Results
- 7.5 Conclusions
- Acknowledgments
- References

## 7.1 INTRODUCTION

Predictive food microbiology essentially aims at the quantification of the microbial ecology in foods by means of mathematical models.<sup>1</sup> These models can then be used to predict food safety and shelf life, to develop and assist in safety assurance systems in the food industry (e.g., Hazard Analysis of Critical Control Points), and to establish





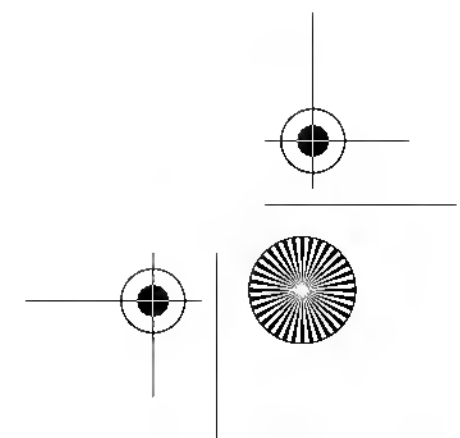
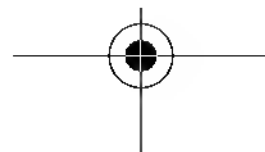
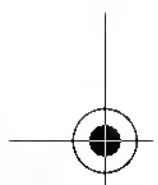
exposure studies in the framework of risk assessment (see, e.g., References 2 to 4). Though challenge testing tends to be the common policy in the food industry, information on microbial kinetics — in food products — is increasingly consolidated into mathematical models, which may significantly reduce the number of challenge tests required to determine, for example, shelf life. In combination with predictive models for, e.g., heat transfer, and other process variables, and the initial contamination level, these models are essential building blocks in time-saving simulation studies to optimize and design processing, distribution, and storage conditions (e.g., temperature–time regimes) that guard food safety and spoilage (e.g., Reference 5).

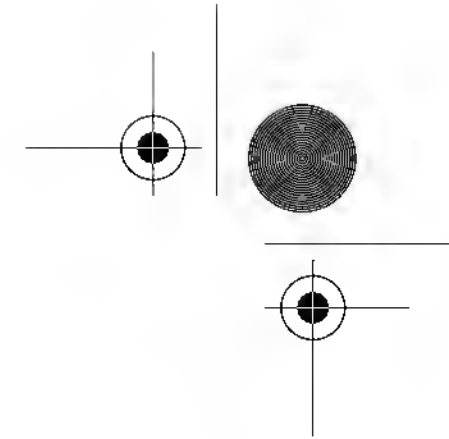
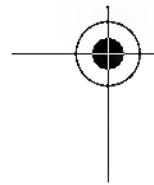
In the early years of predictive microbiology, strong preference has been expressed towards sigmoidal functions that gave a good description of growth curves obtained under nonvarying environmental conditions. The most commonly used growth model was probably the modified Gompertz model.<sup>6</sup> Microbial inactivation at high temperatures — exhibiting a log-linear behavior — could be described as a first-order decay reaction (see, e.g., Reference 7). Effects of environmental conditions on these *primary* models (i.e., evolution of cell number as function of time) are embedded into *secondary* models (see Chapter 2 and Chapter 3 for more details). *Dynamic primary models* capable of (1) dealing with realistic *time-varying conditions* and (2) including the previous *history* of the food product in a natural way have been introduced since the early nineties.<sup>8,9</sup>

Besides the need for such dynamic models, it is also clear that real food product conditions should be taken into account during modeling (e.g., Reference 10). More (mechanistic) knowledge needs to be built into existing models such that the physiological response of microorganisms and the associated microbial dynamics can be accurately explained under fluctuating conditions. For example, reliable predictions for microbial lag phenomena and interaction are lacking nowadays.

In this chapter, the elementary building block for dynamic mathematical models describing microbial evolution is presented (see Section 7.2). Given this general expression, (mechanistic) knowledge on the microbial behavior in foods can be gradually built in to yield a generic model structure describing the microbial dynamics of interest. During this model development process, a continuous trade-off needs to be made between *model complexity* and *manageability*. On the one hand, the mathematical model should incorporate sufficient (mechanistic) knowledge in order to generate *accurate* predictions. Reliable predictions are indispensable to advocate confidence in predictive microbiology within the food industry. On the other hand, these mathematical models must remain user-friendly and computationally manageable in view of their industrial applicability.

The chapter is organized as follows. Section 7.2 introduces the general dynamic model building approach. First, this strategy is illustrated for modeling simple growth and inactivation behavior. However, accurate modeling of microbial dynamics in foods usually requires more complex model structures. In this respect, (1) the modeling of microbial lag under time-varying temperature conditions via an individual-based approach (see Section 7.3) and (2) the modeling of interspecies microbial interactions mediated by product inhibition (see Section 7.4) are discussed. At the same time, the fundamentals of microscopic (*individual-based*) and macroscopic (*population level*) modeling are revisited. Section 7.5 summarizes the general conclusions.





## 7.2 GENERAL DYNAMIC MODELING METHODOLOGY

The elementary dynamic model building block describing microbial dynamics under batch cultivation within a homogeneous environment consists of the following differential equation:

$$\frac{dN_i(t)}{dt} = \mu_i(N_i(t), \langle N_j(t) \rangle_{i \neq j}, \langle env(t) \rangle, \langle P(t) \rangle, \langle phys(t) \rangle, \dots) \cdot N_i(t) \quad (7.1)$$

with  $i, j = 1, 2, \dots, n$  the number of microbial species involved (analogous with Reference 11).  $N_i(t)$  represents the cell density of species  $i$  and  $\mu_i(\cdot)$  [ $\text{h}^{-1}$ ] defines its *overall specific evolution rate* depending on interactions within and/or between microbial populations ( $N_i$  and/or  $N_j$ , respectively), physicochemical environmental conditions ( $\langle env \rangle$ ), microbial metabolite concentrations ( $\langle P \rangle$ ), the physiological state of the cells ( $\langle phys \rangle$ ), among others. Microbial proliferation is generated when  $\mu_i(\cdot) > 0$  and microbial decay results from  $\mu_i(\cdot) < 0$ .

Observe that all influencing factors may depend on time themselves. For example, temperature may change dynamically with time, and thus acts as an *input* when solving the system of differential equations. To describe the time-dependent evolution of metabolite production and the physiological state of the cells, for example, additional *coupled* differential equations are added to the set of differential equations in 7.1. This is abundantly illustrated throughout the paper.

Within structured food systems, Expression 7.1 describes the *local* dynamic behavior of microorganisms. In such case, local inputs are needed. For example, local temperatures can be computed using heat transfer models. Furthermore, microbial dynamics shall be influenced by spatially varying substrate and nutrient concentrations (which may become restricted because of diffusion limitations). Diffusion limitations also cause spatial gradients of metabolic products. In addition, the need for a valid *transport* model for microbial growth (i.e., describing spatial colony dynamics) rises (e.g., Reference 12).

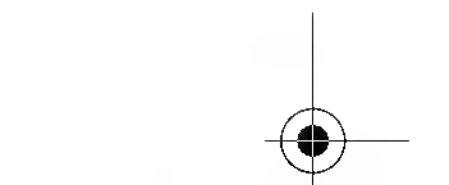
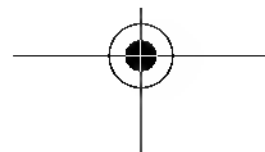
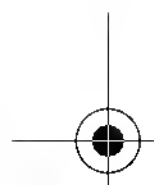
### 7.2.1 BASIC ELEMENTS FOR MODELING GROWTH

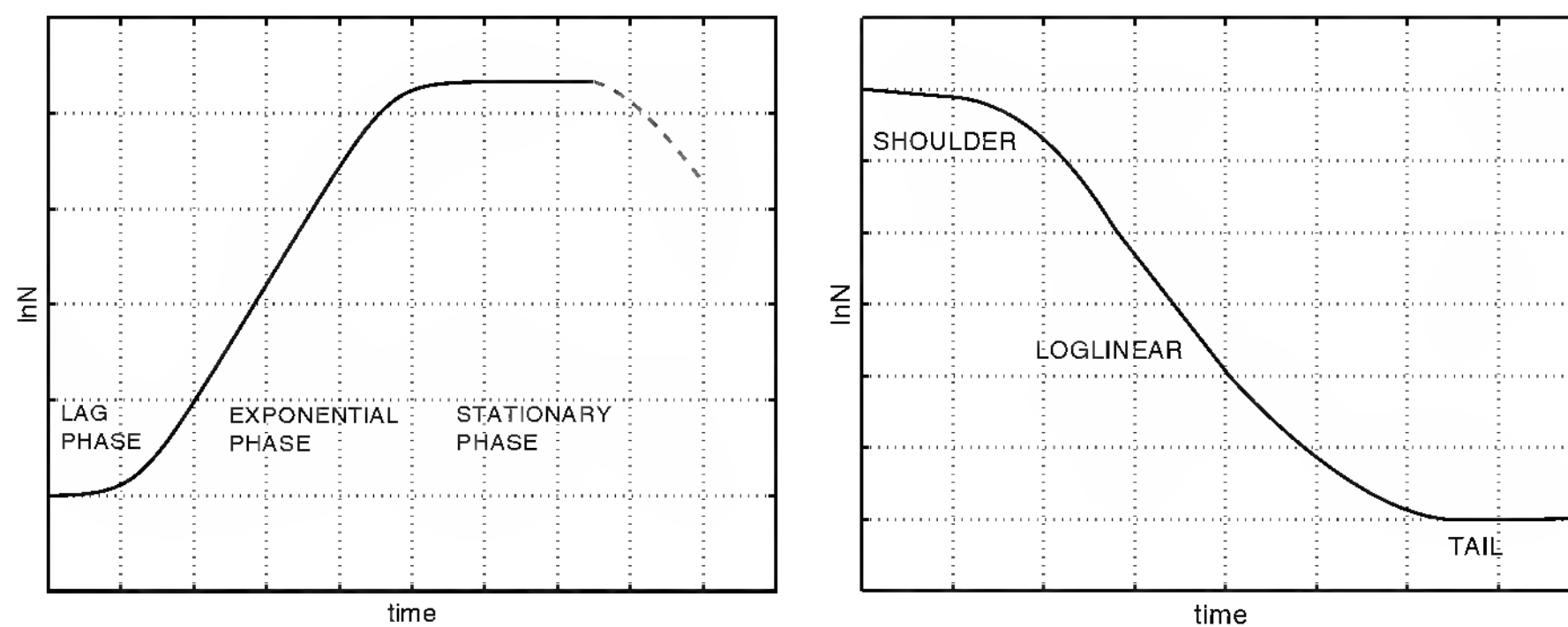
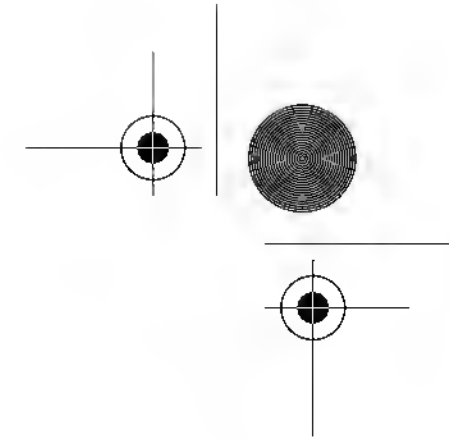
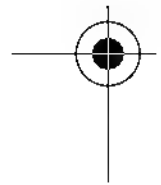
If environmental conditions are constant, the microbial growth curve — the (natural) logarithm of the cell density as function of time — typically exhibits a sigmoidal shape consisting of three phases: the lag phase, the exponential phase and the stationary phase (see Figure 7.1). First, the population needs to adjust to its new environment. Second, the population attains its maximum specific growth rate characteristic for the specific environment. Third, growth ceases because of, e.g., inhibitory effects of metabolites. Eventually, this leads to inactivation.

The overall specific growth rate in Expression 7.1 can be represented by three factors describing these three phases\*:

---

\* The dynamics of a single species are considered and the subscript  $i$  can thus be omitted.





**FIGURE 7.1** Left plot: Typical growth curve (full line) at constant environmental conditions. Right plot: Typical inactivation curve under mild constant processing conditions.

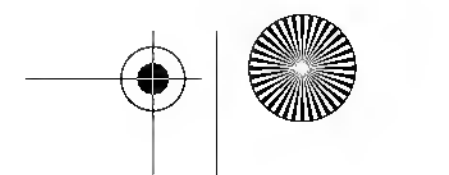
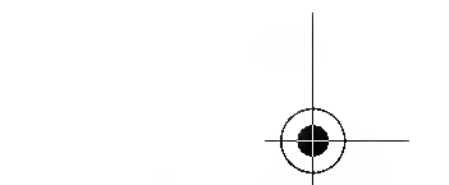
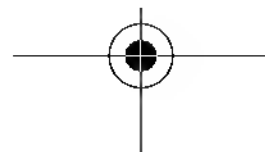
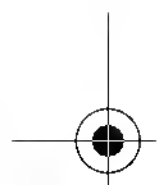
$$\frac{dN(t)}{dt} = \mu_{lag}(\cdot) \cdot \mu_{max}(\cdot) \cdot \mu_{stat}(\cdot) \cdot N(t) \quad (7.2)$$

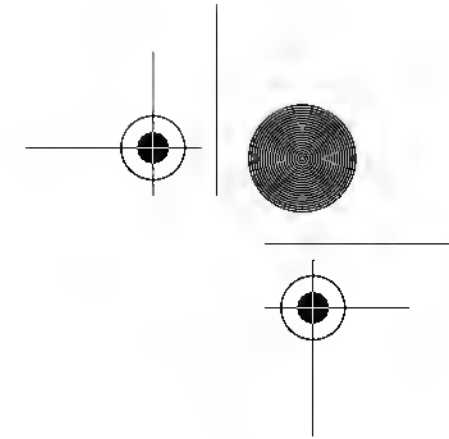
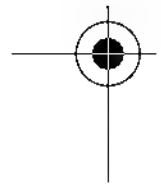
During the exponential phase, the specific growth rate remains constant at  $\mu_{max}$ , which is the maximum specific growth rate that can be realized within the actual environment. The dependence on environmental factors such as temperature is typically incorporated into secondary models (e.g., Reference 13). The first factor  $\mu_{lag}(\cdot)$  is introduced to describe the lag behavior and thus needs to embed the gradual increase of the overall specific growth rate from 0 to  $\mu_{max}$ . The third factor  $\mu_{stat}(\cdot)$  induces the gradual decrease in the specific growth rate towards 0, resulting in the stationary phase.

Dynamic models in predictive microbiology are reported in, e.g., Baranyi and Roberts,<sup>14</sup> Baranyi et al.,<sup>8</sup> Hills and Mackey,<sup>15</sup> Hills and Wright,<sup>16</sup> McKellar,<sup>17</sup> and Van Impe et al.<sup>9,18</sup> A well-known dynamic model is the growth model by Baranyi and Roberts:<sup>14</sup>

$$\begin{aligned} \frac{dN(t)}{dt} &= \left[ \frac{Q(t)}{1+Q(t)} \right] \cdot \mu_{max} \cdot \left[ 1 - \frac{N(t)}{N_{max}} \right] \cdot N(t) \\ \frac{dQ(t)}{dt} &= \mu_{max} \cdot Q(t) \end{aligned} \quad (7.3)$$

Recognize the three factors in the right-hand side of the first equation as presented in Equation 7.2. The first factor, i.e., the so-called adjustment function, describes the gradual adaptation of the population to attain  $\mu_{max}$ . Hereto, an additional state variable  $Q(t)$  is introduced into the model [thus  $\mu_{lag}(Q(t))$ ]. This variable denotes the physiological state of the cells that should augment until the adjustment function reaches (approximately) its maximum value, namely, 1. At that point, the exponential phase starts. The initial value of  $Q(t)$  together with the maximum specific growth rate determines the lag-phase duration. Graphically,  $\mu_{max}$  corresponds with the slope





of the log-linear part of the growth curve.\* The third factor, i.e., the so-called inhibition function, causes the growth rate to decrease asymptotically to 0 when the population density reaches its maximum level  $N_{\max}$  [thus  $\mu_{\text{stat}}(N(t), N_{\max})$ ].

Environmental conditions affecting the outgrowth of microorganisms in food products are often time-varying. In such case, predictions of the food safety and the shelf life can be generated by combining a dynamic primary model with a secondary model relating the typical primary parameters with environmental conditions (e.g.,  $\mu_{\max}(\langle env(t) \rangle)$ ). Doing so, it is implicitly assumed that the primary parameters, e.g., the maximum specific growth rate, immediately change according to the changing environmental factors and the secondary model. Consequently, delayed responses (lag) induced by (sudden) fluctuations of the surrounding environment cannot be predicted.<sup>19</sup> Furthermore, the cessation of growth is a response to starvation following exhaustion of nutrients and/or the inhibition by metabolic products.<sup>20</sup> Description of the inhibition within mixed cultures by, e.g., product formation, cannot be consistently described when using the single model parameter  $N_{\max}$  (see below).

Section 7.3 and Section 7.4 illustrate how such dynamic growth models (7.2) can be *fine-tuned* towards the modeling of microbial lag and growth inhibition. Eventually, we aim at robust mechanistically inspired models.

### 7.2.2 BASIC ELEMENTS FOR MODELING INACTIVATION

During mild heat treatment (at constant temperature) microbial inactivation often shows a non-log-linear behavior characterized by a delayed response (*shoulder*) and a resistant population (*tailing*) (see Figure 7.1, right plot). According to Expression 7.1, a general model structure reads as follows.\*\*

$$\frac{dN(t)}{dt} = -k_{\text{shoulder}}(\cdot) \cdot k_{\text{max}}(\cdot) \cdot k_{\text{tail}}(\cdot) \cdot N(t) \quad (7.4)$$

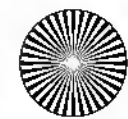
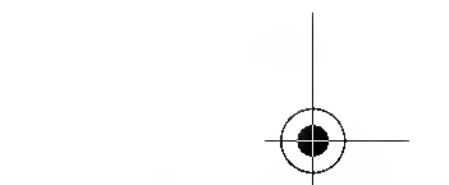
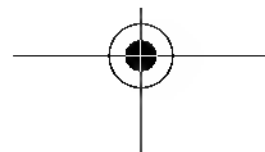
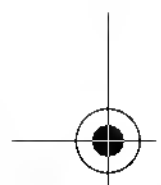
To express the specific microbial inactivation rate the symbol  $k$  is commonly used.

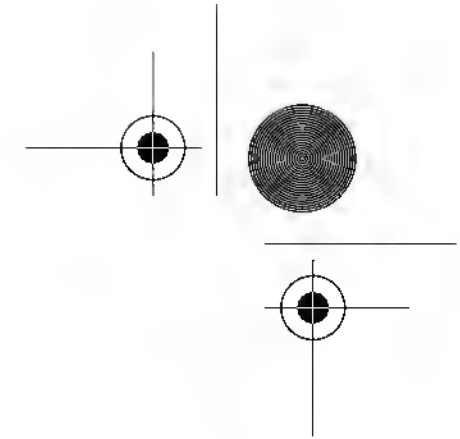
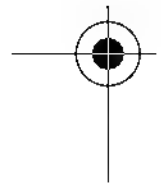
On the basis of the mechanistic insight on the occurrence of the shoulder and tailing phenomenon,<sup>21–24</sup> Geeraerd et al.<sup>25</sup> established the following functions modeling the shoulder and tailing behavior.

$$\begin{aligned} \frac{dN(t)}{dt} &= - \left[ \frac{1}{1 + C_c(t)} \right] \cdot k_{\text{max}} \cdot \left[ 1 - \frac{N_{\text{res}}}{N(t)} \right] \cdot N(t) \\ \frac{dC_c(t)}{dt} &= -k_{\text{max}} \cdot C_c(t) \end{aligned} \quad (7.5)$$

\* From a mathematical point of view, the adjustment function is exactly equal to 1 only at infinity, whereas the inhibition function approximates 1 when  $N(t) \ll N_{\max}$ . However, from a numerical point of view, both factors are 1 during a considerable part of the growth curve. Hence, it can be reasonably said that during the log-linear part  $\mu_{\max}$  is reached.

\*\* Here too the dynamics of a single species are considered and the subscript  $i$  can thus be omitted.





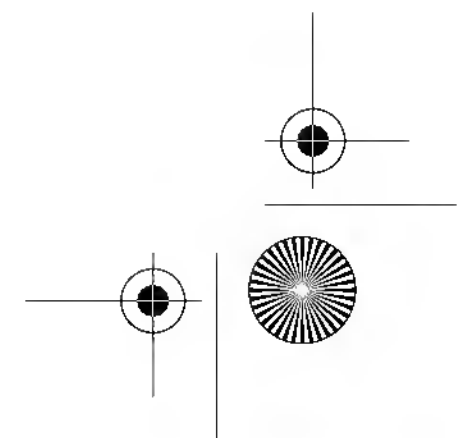
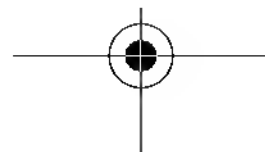
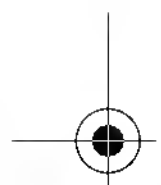
The first factor in the right-hand side of the first equation models the shoulder of the inactivation curve. Before first-order inactivation of the population takes place (at a specific inactivation rate  $k_{\max}$ ), some critical protective component  $C_c$  needs to be inactivated. It is assumed that this occurs according to a first-order relationship (i.e., second differential equation in 7.5). The shoulder is obtained by applying a Michaelis–Menten-based adjustment function, namely,  $(1 + C_c(t))^{-1}$  [thus  $k_{\text{shoulder}}(C_c(t))$ ]. Starting at a low value, the adjustment function increases towards unity and, at that point, log-linear inactivation is observed. Analogous with the physiological state  $Q(t)$  in the dynamic growth model 7.3,  $C_c(t)$  can be interpreted as the physiological state of the population in the context of inactivation. The tailing phenomenon can be explained by some resistant subpopulation  $N_{\text{res}}$  that is unaffected during the (heat) treatment. This tailing at a residual population  $N_{\text{res}}$  is here modeled by  $(1 - N_{\text{res}}/N(t))$  [thus  $k_{\text{tail}}(N(t), N_{\text{res}})$ ]. Note that this residual subpopulation is not necessarily a constant value but may vary when modeling nonthermal inactivation,<sup>26,27</sup> or when subjecting the microbial population to sequences of inactivation treatments.<sup>28</sup>

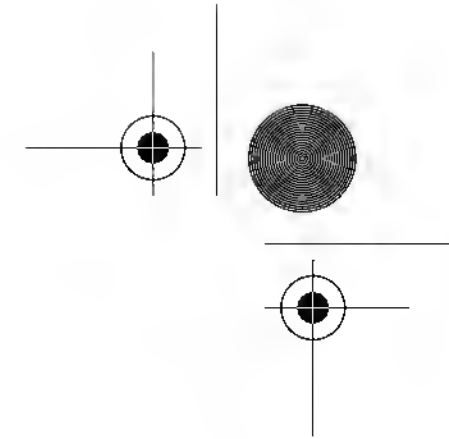
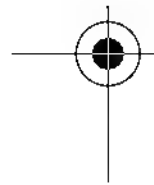
To conclude, observe that the general model structure 7.4 and model 7.5 also encompass classical log-linear inactivation. In Equation 7.5, log-linear inactivation is generated by selecting (after identification on experimental data) a very low value for  $C_c(0)$  and  $N_{\text{res}}$ , implying the absence of a shoulder and a tail, respectively.

### 7.3 EXAMPLE I: INDIVIDUAL-BASED MODELING OF MICROBIAL LAG

Factors affecting the occurrence and extent of the commonly observed *initial* (population) lag phase (i.e., a period after inoculation during which cells adapt themselves to the new environment, see Figure 7.1) can be attributed to the past environment, the new environment, the magnitude of the environmental change, the rate of the environmental change, the growth status (e.g., exponential, stationary) of the inoculated cell culture, and the variability between individual cell lag phases. These environmental changes may involve nutritional and chemical, as well as physical changes. Obviously, environmental fluctuations during exponential growth can also cause lag (i.e., intermediate lag). Large temperature gradients, for example, applied during the exponential growth phase shall induce an intermediate lag phase observed as a transient adaptation of the growth rate.<sup>19,29</sup>

Secondary models describing the relation between the (population) lag-phase duration and the physicochemical environment are usually based on highly standardized experiments during which cells are grown to their stationary phase under optimal growth conditions before being transferred to the new environment, which is not – deliberately — varied upon the subsequent growth. Such mathematical models perform well under the conditions that they have been developed for. However, any deviation within the prehistory of the contaminating population may seriously alter the lag behavior.<sup>30,31</sup> Especially, huge deviations between model prediction and actual microbial dynamics are observed under time-varying environmental conditions.<sup>32</sup>



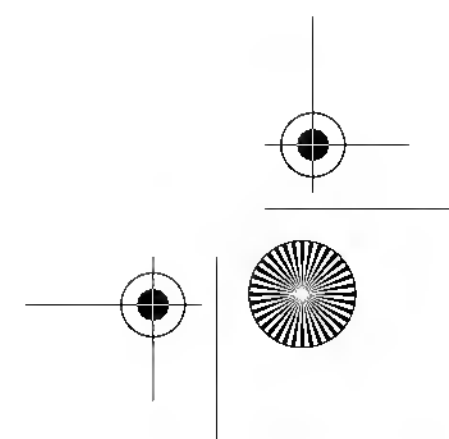
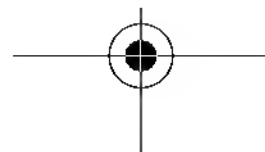
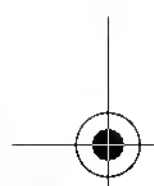
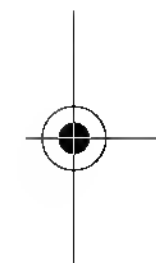
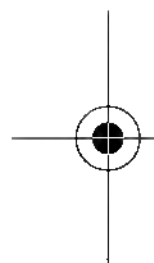


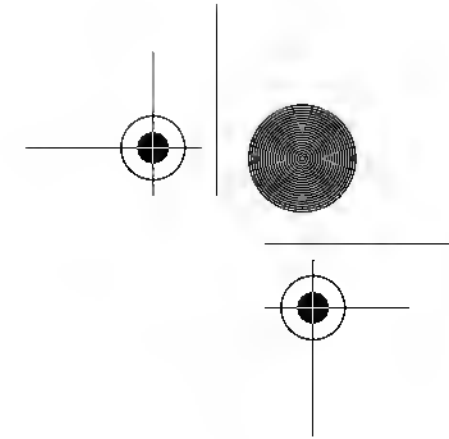
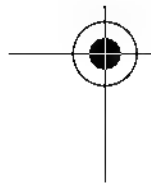
Overall, lag phenomena induced by (sudden) environmental changes are insufficiently explored, and suitable (generic) predictive models are not available. In this section, a first attempt towards a general model structure that is valid for various microorganisms and various dynamic temperature conditions — as presented in Dens<sup>33</sup> — is described. Opposed to the more traditional population modeling approach, basic *mechanistic knowledge* concerning the mechanism causing lag at *cell level* is embedded into the model. In particular, the theory of cell division is implemented within an *individual-based modeling* approach to enable the description of lag phases that can be induced by sudden temperature rises.

### 7.3.1 PRINCIPLES OF INDIVIDUAL-BASED MODELING

The fundamental unit of bacterial life is the cell, encapsulating action, information storage and processing as well as variability. It can therefore be appropriate to construct microbial models in terms of the *individual cells*.<sup>34</sup> This is the domain of *individual-based modeling*. The basic idea behind this approach is that, if it is possible to specify the *rules* governing the behavior of the cells, then the global multicellular behavior can be explained by the interactions between the individual cell activities. The rules constituting the model reflect the (presumed) behavior of the individual cells, such as nutrient consumption, biomass growth, cell division, movement, differentiation, communication, maintenance, and death. Since a change in microscopic (individual-based) rules may lead to significantly different macroscopic (population) behavior, it might be possible to rule out impossible mechanisms and to learn about the true mechanisms. A very important property of individual-based models is the fact that they easily allow for differences between the individuals. This is accomplished by using random variables, drawn from a certain statistical distribution. The introduction of a range of randomness and the consideration of a high number of individuals interacting independently with the environment leads to a good representation of reality and leads to a better understanding of the cellular metabolism (see, e.g., Reference 35). Spatial effects can be relatively easily translated into a set of rules. Kreft et al.<sup>34</sup> introduced the spatial aspect in their model to reproduce the growth of *Escherichia coli* cells in a colony.

In general, individual-based models incorporating underlying mechanistic knowledge of microbial dynamics are widely spread, but are relatively unexplored in the field of predictive microbiology. The more general modeling approach in predictive microbiology considers the microbial population as such, i.e., the population is described by a single-state variable, namely,  $N(t)$ . Furthermore, model parameters are usually assumed to be deterministic, i.e., have one typical value. When incorporating cell-to-cell variability into population-based models, population-related model parameters are considered as random or distributed variables (e.g., Reference 36). Individual-based models have the advantage that the cell-to-cell variability can be incorporated at cell level, i.e., the level from which variability actually originates. The general concepts of individual-based models and their applicability in the context of predictive microbiology are discussed in Dens.<sup>33</sup>





### 7.3.2 IMPLEMENTATION OF MECHANISTIC INSIGHT INTO AN INDIVIDUAL-BASED MODEL

#### 7.3.2.1 Modeling Mechanistic Insight on the Temperature Dependency of Cell Growth

The mechanistic insight into the *theory of cell division* has been built into an individual-based model BacSim, originally developed by Kreft et al.<sup>34</sup> In contrast to the general expression 7.1 describing the evolution of a bacterial population  $N(t)$ , biomass growth of the individual cells  $m(t)$  is considered and is assumed to occur exponentially at any time\*:

$$\frac{dm(t)}{dt} = \mu_{\max} \cdot m(t) \quad (7.6)$$

This expression forms the elementary building block of the proposed individual-based model.

Concerning the cell cycle of an individual cell, Cooper and Helmstetter<sup>37</sup> observed that, for a constant temperature, a constant time  $C$  is needed for the replication of DNA and a constant time  $D$  for cell division. In combination with the fact that DNA replication is always initiated when the cell attains a certain amount of biomass  $2m_c$ , Donachie<sup>38</sup> derived the following relationship for the amount of biomass at cell division  $m_d$ :

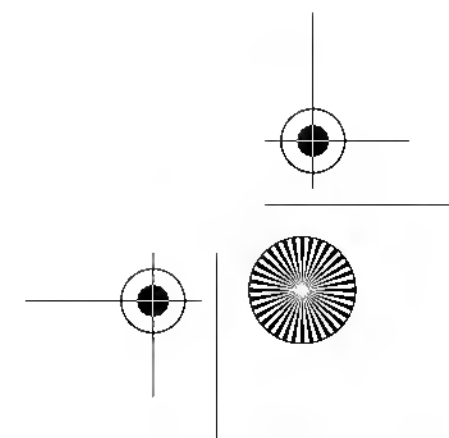
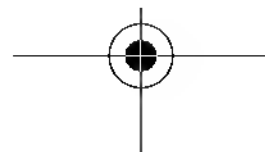
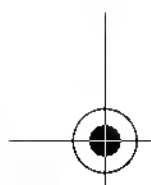
$$m_d = 2m_c \exp(\mu \cdot (C + D)) \quad (7.7)$$

with  $\mu$  the specific growth rate of the cell biomass (in combination with 7.6,  $\mu$  represents  $\mu_{\max}$ ). Following this equation, the cell mass at division (and thus also the average cell mass of the population) is proportional to the exponent of the product  $\mu \cdot (C + D)$ . With respect to this equation and based on literature, a number of hypotheses on the effect of dynamic temperatures on the cell division process (and thus the overall specific cell-number growth rate) can be formulated:

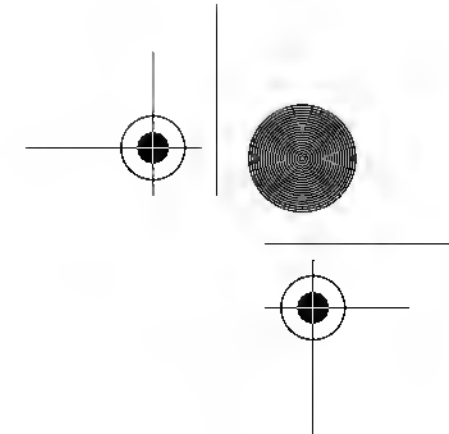
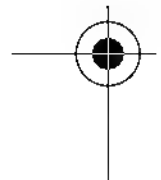
- i. The product  $\mu \cdot (C + D)$  stays constant for different temperature conditions. This means that temperature variations do not alter the size and the chemical composition of the cells, as postulated by Cooper.<sup>39</sup> In other words, the biomass growth rate as well as the population growth rate will immediately change when imposing temperature changes and no lag will be observed.
- ii. Trueba et al.<sup>40</sup> reported that the average cell volume of *E. coli* decreases with decreasing temperatures. Consequently, for these observations, the product  $\mu \cdot (C + D)$  depends on temperature as the average cell volume is proportional to  $m_d$ . In case of a temperature increase, for example, the

---

\* The dynamics of a single species are considered and the subscript  $i$  can thus be omitted.







- biomass growth rate will instantaneously change but the population number will lag behind as the average volume for division has increased.
- iii. A lag in biomass growth of *E. coli* induced by sudden temperature shifts from low to high temperatures has been reported by Ng et al.<sup>41</sup> The authors assume that cells growing at low temperatures express some *damaged* status that needs to be *repaired* before active growth at high temperatures can be achieved. This damaged state can be reflected by a limiting concentration of one or more enzymes. When passing from a low to a high temperature, cells first need to increase the concentration of these limiting enzymes, before they can increase their biomass growth rate.

A (simplified) mathematical translation of this hypothesis reads as follows:

$$\frac{dm(t)}{dt} = \frac{E(t)}{m(t)} \cdot \frac{\mu_{\max}(T(t))}{L} \cdot m(t) = \mu(\cdot) \cdot m(t)$$

$$\text{with } \frac{dE(t)}{dm(t)} = L \quad (L = L_l \text{ or } L_h)$$

with  $E(t)$  some critical growth factor, and  $L$  the rate at which  $E$  is synthesized (after Reference 41). This production rate changes according to temperature (in a discrete way), i.e.,  $L_l$  and  $L_h$  are the typical production rates for low and high temperatures, respectively. For *E. coli* populations, the high temperature zone ranges from 20 to 37°C and is also known as the normal physiological range of *E. coli*.<sup>41</sup>

In conclusion, this hypothesis will predict a lag phase when temperature variations cross the (lower) boundary of the normal physiological range.

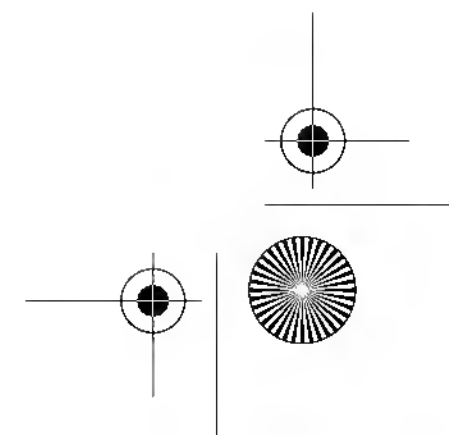
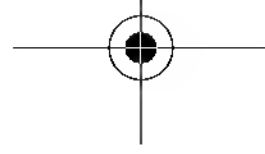
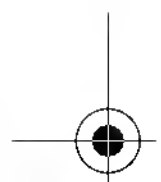
The temperature dependence in the suboptimal growth temperature range can be modeled by the square root model of Ratkowsky et al.<sup>42</sup>:

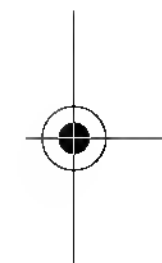
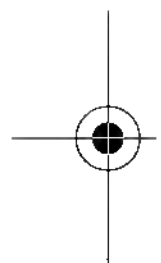
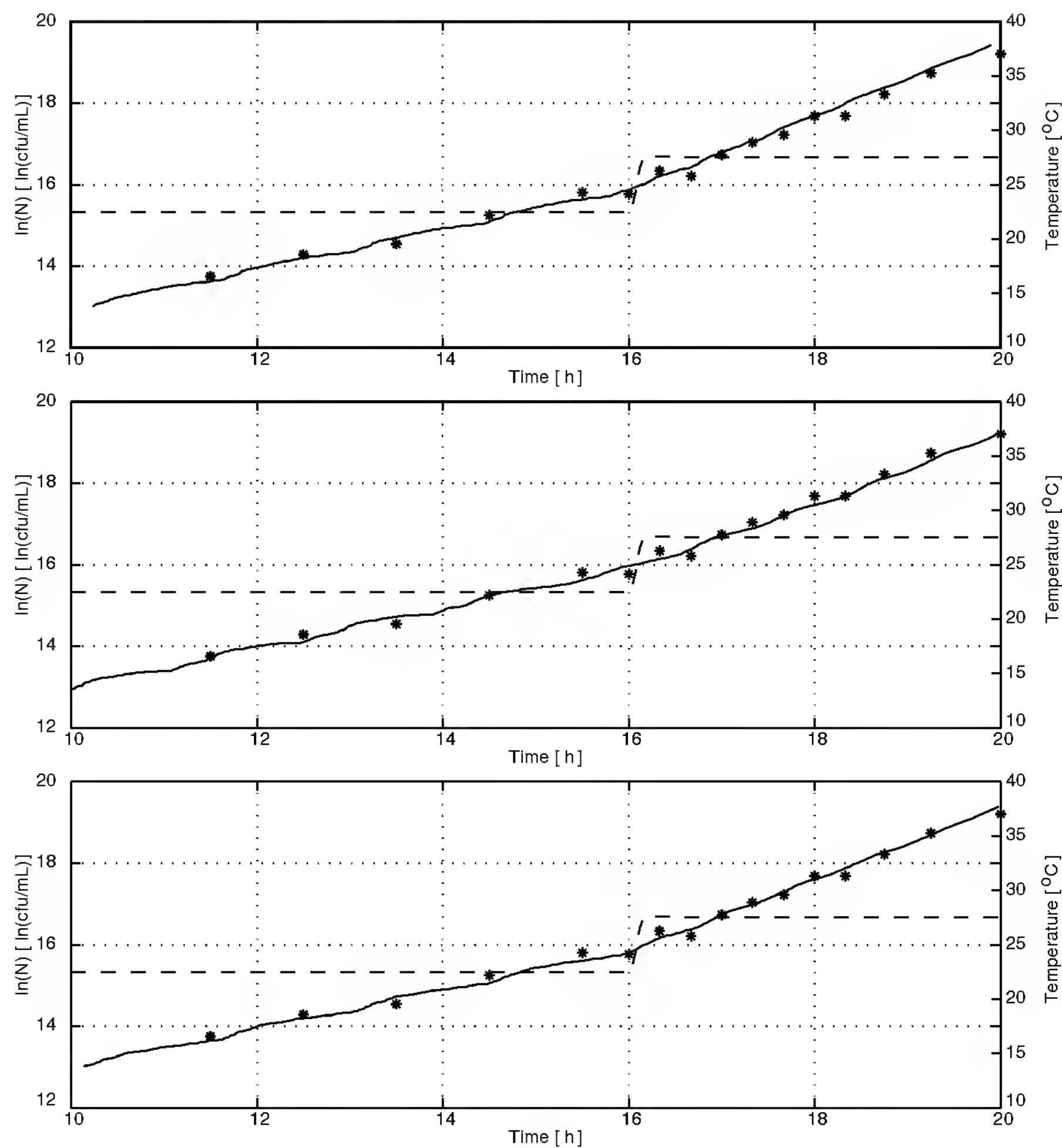
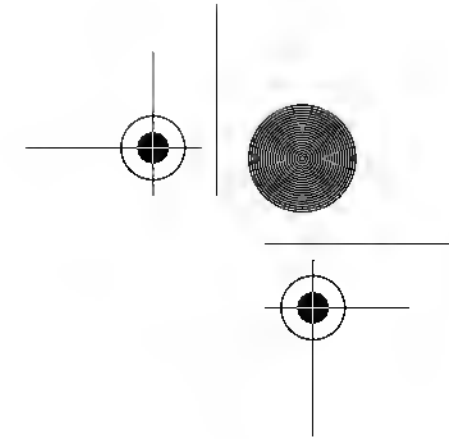
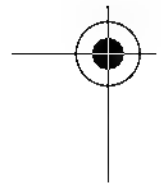
$$\sqrt{\mu_{\max}(T(t))} = b \cdot (T(t) - T_{\min}) \quad (7.8)$$

For more details on the exact implementation (i.e., parameter values, initial conditions, etc.) of these hypotheses, reference is made to Dens.<sup>33</sup>

### 7.3.2.2 Simulation Results

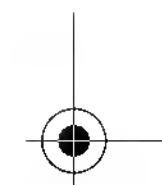
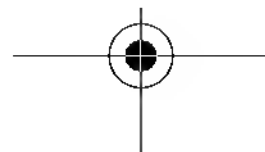
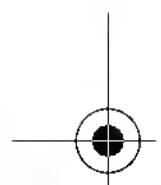
As a case study, the effect of abrupt shift-up temperatures on the growth of *E. coli* is described. The experimental data in Figure 7.2 and Figure 7.3 depict the effect of a small (i.e., 5°C) and a large (i.e., 20°C) positive temperature shift on the growth of *E. coli*, respectively. Full details on the experimental data generation can again be found in Bernaerts et al.<sup>19</sup> and Dens.<sup>33</sup>

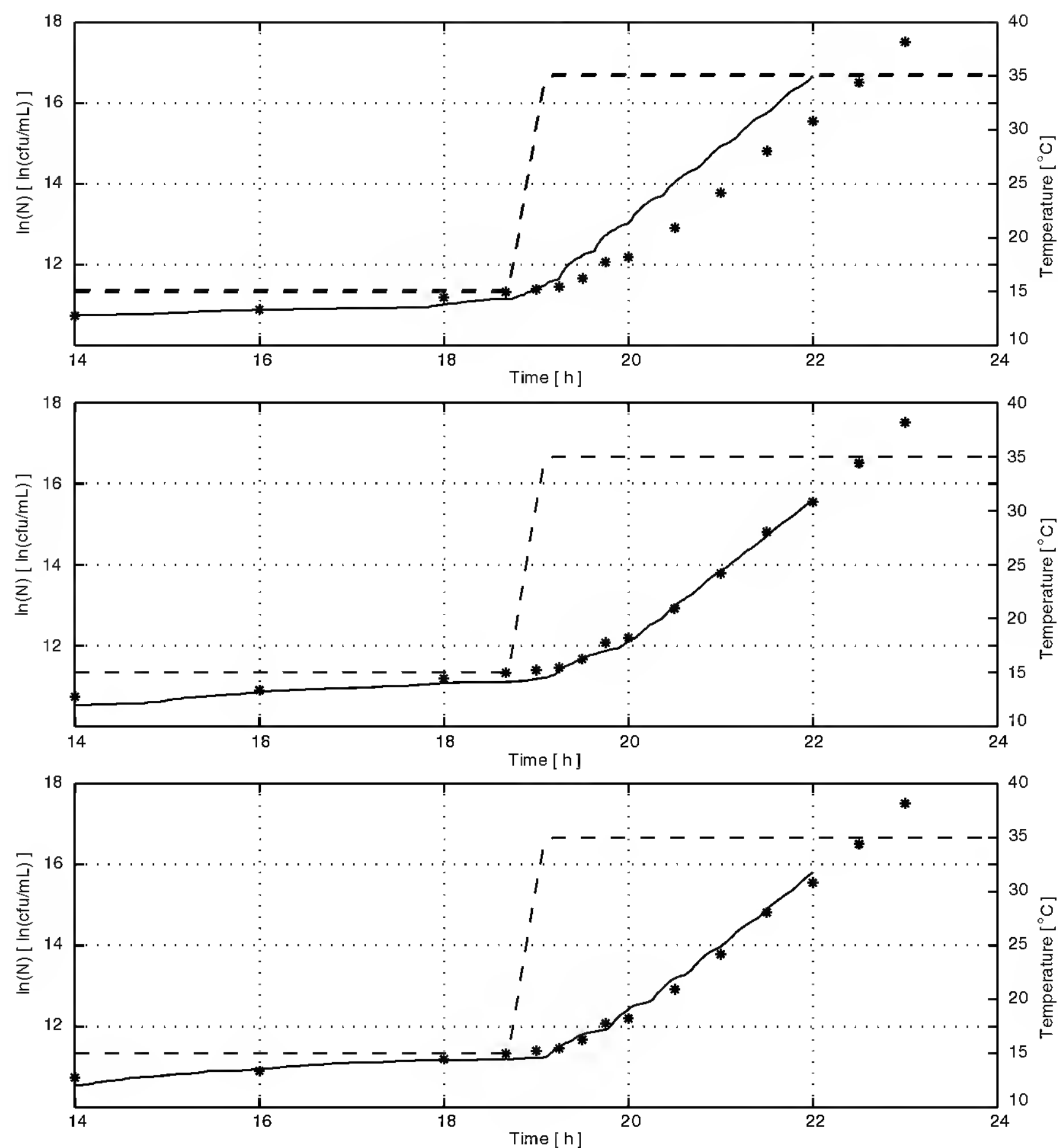
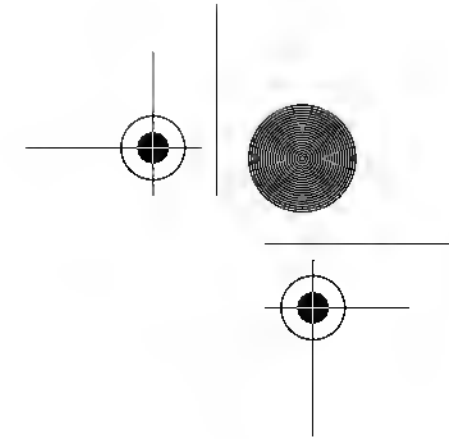
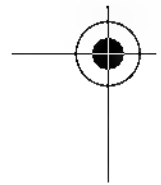




**FIGURE 7.2** Simulation of the individual-based models proposed in Section 7.3 on experimental data of *E. coli* (\*) submitted to a sudden temperature shift from 22.5 to 27.5°C during exponential growth (Adapted from Dens, E.J., *Predictive Microbiology of Complex Bacterial/Food Systems: Analysis of New Modelling Approaches*, Katholieke Universiteit Leuven, Belgium, 2001). The solid line represents the model prediction using the measured temperature profile (dashed line). Top: hypothesis (i), middle: hypothesis (ii), bottom: hypothesis (iii).

For each of the temperature shifts, the three hypotheses described in the previous paragraph have been implemented. It appears from Figure 7.2 that the small temperature increase from 22.5 to 27.5°C does not alter the balanced growth dynamics of the microorganisms and is properly described in all three cases. On the contrary, cell density data generated during the larger temperature shift from 15°C (low temperature range) to 35°C (high temperature range) induces a lagged growth response that can be predicted by only hypotheses (ii) and (iii) (see Figure 7.3). In hypothesis (ii), the lag phase is due to the time needed to increase the cell volume up to the new critical



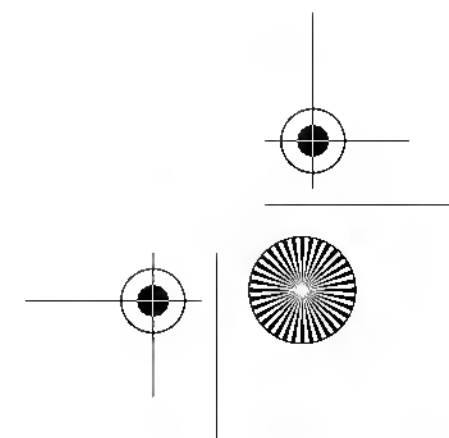
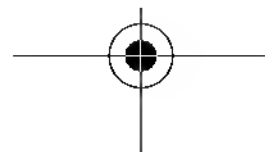
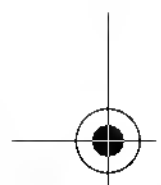


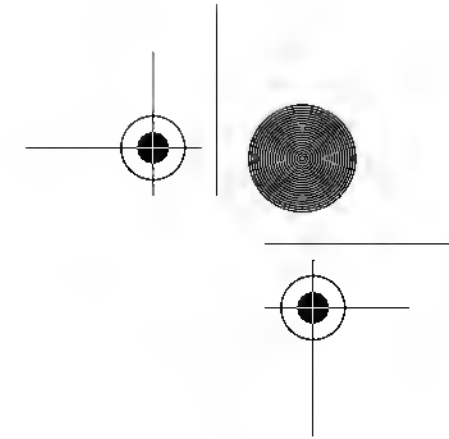
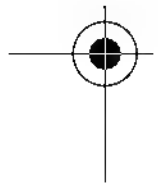
**FIGURE 7.3** Simulation of the individual-based models proposed in Section 7.3 on experimental data of *E. coli* (\*) submitted to a sudden temperature shift from 15 to 35°C during exponential growth (Adapted from Dens, E.J., *Predictive Microbiology of Complex Bacterial/Food Systems: Analysis of New Modelling Approaches*, Katholieke Universiteit Leuven, Belgium, 2001). The solid line represents the model prediction using the measured temperature profile (dashed line). Top: hypothesis (i), middle: hypothesis (ii), bottom: hypothesis (iii).

mass at division. Biomass growth exhibits an immediate rate adjustment whereas cell number shows lag behavior. In hypothesis (iii), the lag phase is reproduced at the level of biomass growth and propagates into the cell number evolution.

### 7.3.2.3 Discussion of Results

Individual-based modeling yields an excellent tool to integrate mechanistic knowledge at the level of the individual cell behavior into a model structure. Simulations with the individual-based model can then explain the population dynamics.





In this example, three cell mechanisms describing the effect of dynamic temperatures could be extracted from literature references. Two of the three hypotheses could describe both a small and a large temperature shift equally well. Given only population density measurements, it is therefore impossible to *discriminate* between the established models. At this point, additional (more advanced) measurements are needed to further establish the model structure. Such more advanced measurements can be biomass weight, DNA concentration, RNA concentration, protein concentration, etc. In other words, the revised modeling example clearly points out the *two-way interaction* between *model building* and *data generation*. Besides the selection of essential measurements, this two-way interaction embraces the design of *informative* experiments, i.e., the selection of appropriate (*dynamic*) input conditions (see, e.g., References 19 and 43) or (*static*) treatment combinations (see, e.g., References 44 and 45).

A disadvantage of the individual-based modeling approach is that the models may become relatively complex and computationally tedious. However, the obtained mechanistic knowledge can eventually form a sound basis for population-based models (which are more easily manageable).

## 7.4 EXAMPLE II. MODELING MICROBIAL INTERACTION WITH PRODUCT INHIBITION

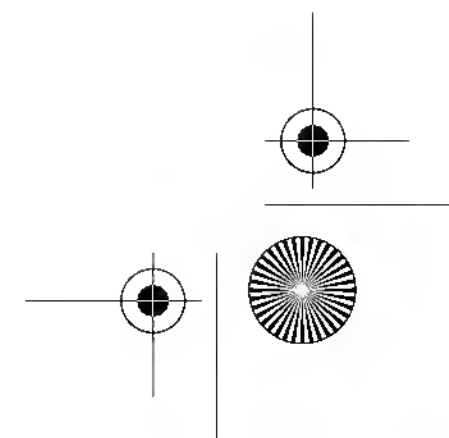
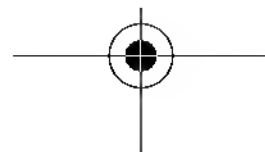
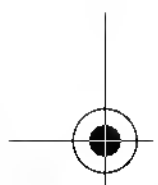
In this section, the interaction of lactic acid bacteria (antagonist) with pathogenic bacteria (target) is discussed and modeled. Information given has been extracted from Vereecken et al.<sup>46-47</sup> and Vereecken and Van Impe.<sup>48</sup>

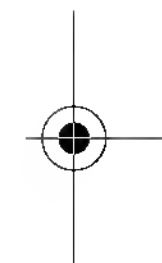
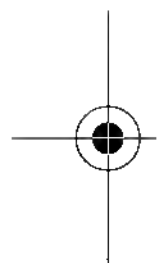
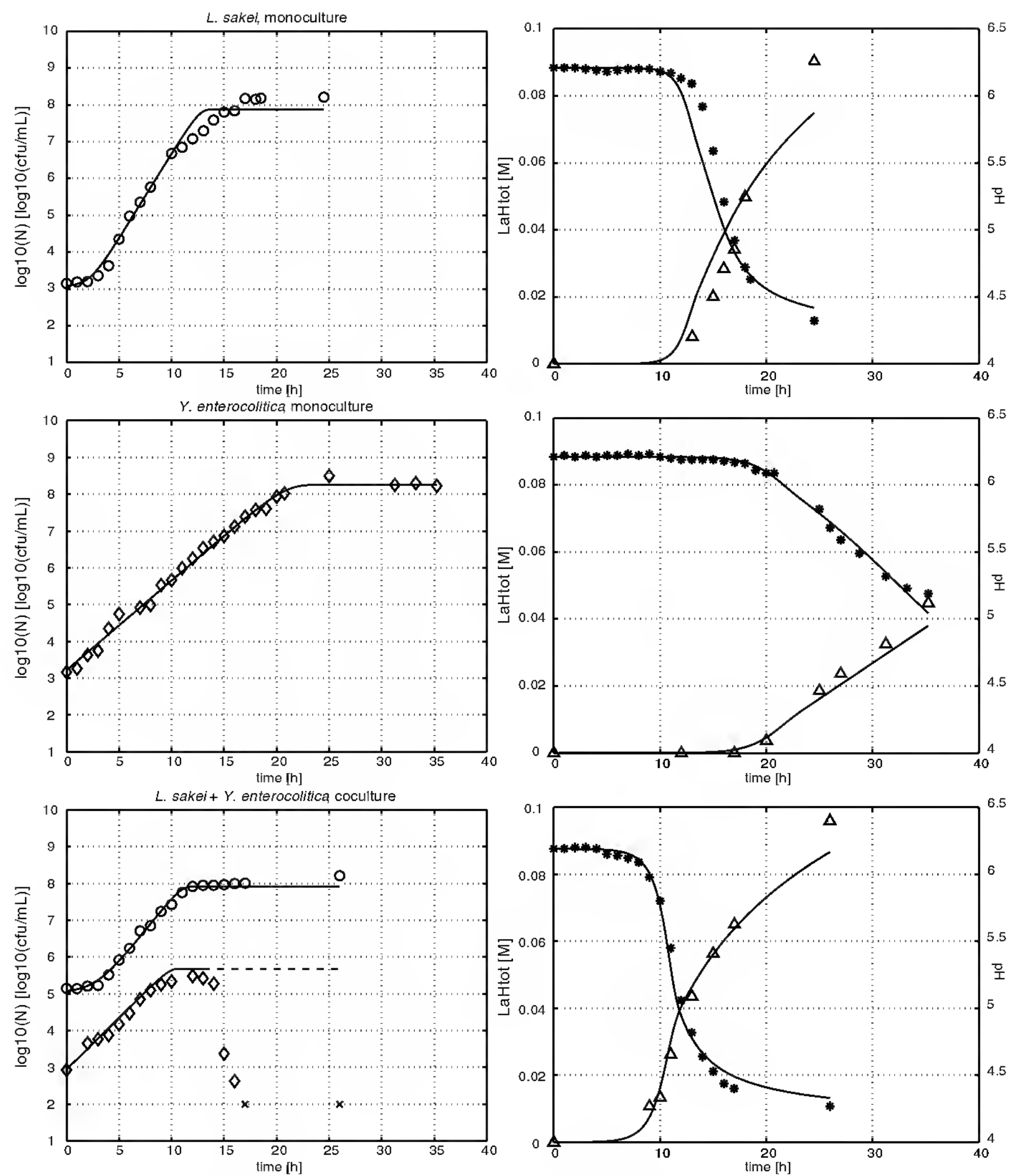
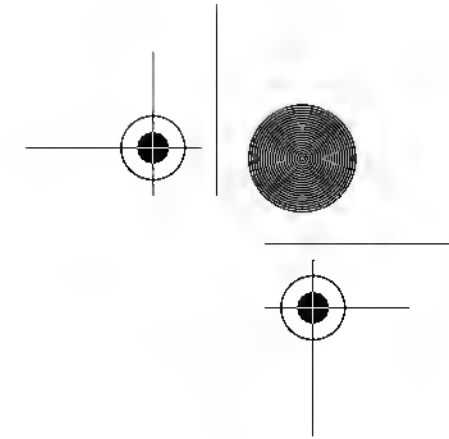
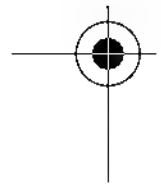
### 7.4.1 DESCRIPTION OF THE INHIBITION PHENOMENA

During the fermentation process of lactic acid bacteria, lactic acid is produced (biological process). This lactic acid released into the medium will dissociate and lower the medium pH (chemical process). Both the undissociated lactic acid concentration ([LaH]) and the decreased pH ( $\sim[H^+]$ ) have an inhibitory effect on microorganisms. In the first place, the lactic acid production will cause the inhibition of the bacterium growth itself. The cessation of growth observed as the stationary phase can thus be attributed to a self-induced inhibitory effect. In addition, this lactic acid production affects neighboring microorganisms. Pathogenic bacteria, like *Yersinia enterocolitica* (see Figure 7.4), can be very sensitive to this inhibitory compound.<sup>24</sup> The increasing lactic acid concentration will cause an early termination of the growth process. For this reason, lactic acid bacteria can be exploited as a natural antimicrobial agent within (fermented) food products or as a protective culture.

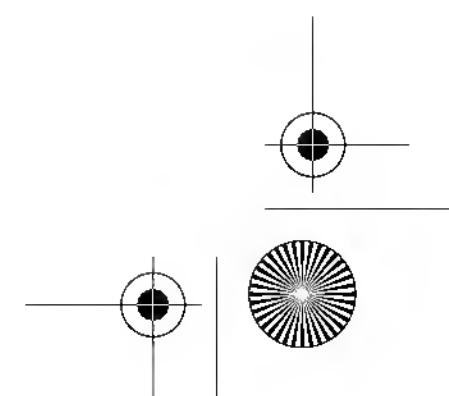
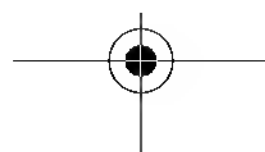
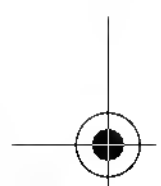
### 7.4.2 MODELING MICROBIAL GROWTH WITH LACTIC ACID PRODUCTION AND INHIBITION

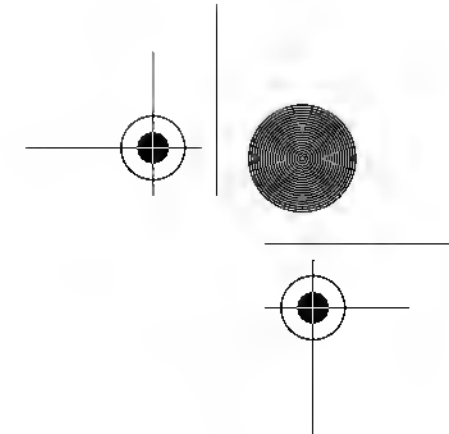
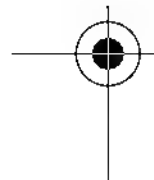
In contrast to the classical approach, Equation 7.3, where the stationary phase is modeled as function of  $N_i(t)$  and  $N_{max}$ , growth inhibition emerges from lactic acid production, which is therefore explicitly incorporated into the model structure:





**FIGURE 7.4** Description of experimental data of *Lactobacillus sakei* (o) and *Yersinia enterocolitica* (◊) grown in mono- and coculture with the dynamic model structures (Equation 7.9 and Equation 7.10 in combination with 7.11 and 7.12) presented in Section 7.4 (Adapted from Vereecken, K.M. and Van Impe, J.F., *Int. J. Food Microbiol.*, 73(2/3), 239, 2002 [ $\times$  refers to cell numbers below detection limit]). The total lactic acid concentration  $[LaH]_{tot}$  ( $\Delta$ ) and pH (\*) are depicted in the right-hand plots. The dissociation kinetics of the applied medium have been computed according to Wilson et al.<sup>49</sup> (Observe that the inactivation of *Y. enterocolitica* cannot be predicted by the model structure [dashed line].)





$$\frac{dN_i(t)}{dt} = \mu_{lag}(\cdot) \cdot \mu_{max}(\cdot) \cdot \mu_{LaH,H^+}([LaH],[H^+]) \cdot N_i(t) \quad (7.9)$$

This general expression describes the growth characteristics of both target and antagonist.\* The growth-related lactic acid production — particularly by the antagonist — requires an additional coupled differential equation:

$$\frac{d[LaH]_{tot,i}(t)}{dt} = \pi(\cdot) \cdot N_i(t) \quad (7.10)$$

with  $\pi(\cdot)$  the specific lactic acid production rate of the antagonistic bacterium (i). Note that  $[LaH]_{tot}$  refers to the total lactic acid concentration, i.e., the sum of the undissociated and dissociated lactic acid concentration. In case multiple lactic acid producing strains are present, the overall growth rate of each strain will be affected by the sum of all  $[LaH]_{tot,i}$  concentrations.

To describe the chemical process of lactic acid dissociation in complex media, several methods inspired by traditional chemical laws are available (e.g., References 48 and 49). Given the medium, the process of lactic acid dissociation can be fully identified irrespective of the microbial model. Observe that  $[LaH]$  and  $[H^+]$  vary with time and are determined by the lactic acid producing strain and the dissociation properties of  $[LaH]_{tot}$  in the growth medium.

Several inhibitory functions can be proposed for  $\mu_{LaH,H^+}([LaH],[H^+])$ . On the basis of a rigorous model structure evaluation, Vereecken et al.<sup>48</sup> translated the inhibitory effect of undissociated lactic acid and the proton concentration (pH) into the following equation:

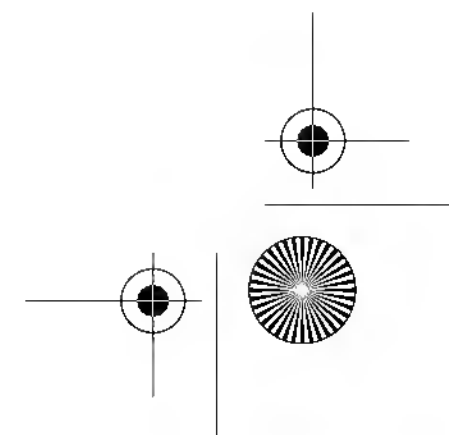
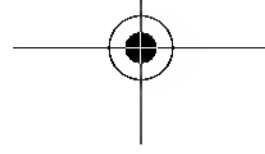
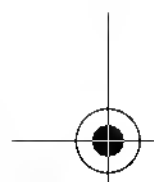
$$\begin{aligned} \mu_{LaH,H^+} &= \left(1 - \frac{[LaH]}{[LaH]_{max}}\right)^\alpha \cdot \left(1 - \frac{[H^+]}{[H^+]_{max}}\right)^\beta && \text{when } [LaH] \leq [LaH]_{max} \\ & && \text{and } [H^+] \leq [H^+]_{max} \\ &= 0 && \text{when } [LaH] > [LaH]_{max} \\ & && \text{or } [H^+] > [H^+]_{max} \end{aligned} \quad (7.11)$$

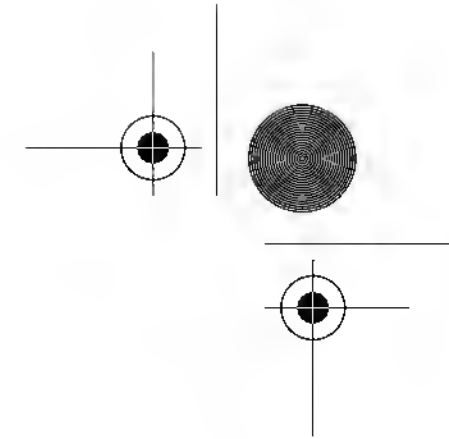
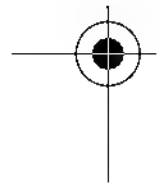
with  $[LaH]_{max}$  the lactic acid concentration at which growth ceases,  $[H^+]_{max}$  the proton concentration associated with the minimum pH for growth, and  $\alpha$  and  $\beta$  some small positive values. The inhibition terms have no effect on the microbial dynamics as long as the undissociated lactic acid concentration and proton concentration remain well below their inhibitory value. In such cases, both functions are approximately equal to 1. When  $[LaH]$  and  $[H^+]$  become significant as time proceeds, either function evolves towards 0 and growth stagnates.

To complete the model structure, the specific lactic acid production rate needs to be mathematically modeled. Combining the traditional linear law with the concept

---

\* The subscript  $i$  thus refers to either the antagonist or the target.





of metabolism inhibitory concentrations,  $\pi(\cdot)$  in Equation 7.10 can be represented as follows:

$$\pi(\cdot) = \underbrace{Y_{LaH/N_i}}_{\text{growth}} \cdot \mu_i(\cdot) + \underbrace{Y_{m,i}([LaH], [H^+])}_{\text{maintenance}} \quad (7.12)$$

with  $Y_{LaH/N_i}$  the yield coefficient [mmol cfu<sup>-1</sup>],  $\mu_i(\cdot)$  the overall specific growth rate (embracing the terms  $\mu_{lag}$ ,  $\mu_{max}$ , and  $\mu_{LaH,H^+}$  within Equation 7.9), and  $Y_{m,i}([LaH], [H^+])$  the maintenance coefficient [mmol cfu<sup>-1</sup> h<sup>-1</sup>]. The first factors present the growth-related production. The maintenance coefficient assures the observed production of  $[LaH]_{tot}$  during the first hours of the stationary phase. This maintenance-related production also ceases when some inhibitory proton or undissociated lactic acid concentration is reached.<sup>50</sup>

The general model structure consisting of the coupled differential Equation 7.9 and Equation 7.10 yields accurate prediction for monocultures as well as mixed-culture growth. This is illustrated for experimental data of *Lactobacillus sakei* and *Y. enterocolitica* in Figure 7.4. More details on parameter values and the practical model implementation are available in References 46 to 48.

### 7.4.3 DISCUSSION OF RESULTS

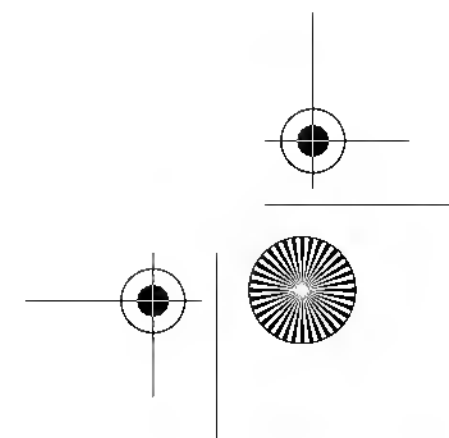
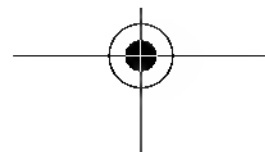
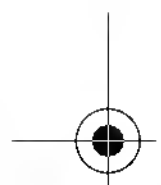
The model building strategy described in this example starts from the identification of main phenomena determining the dynamics of the microbial system. The derived general model structure allows the stationary phase to be described in a natural (mechanistically sound) and consistent way. Moreover, the mechanistically inspired model structure can easily describe both single species and multiple species dynamics (with interaction).

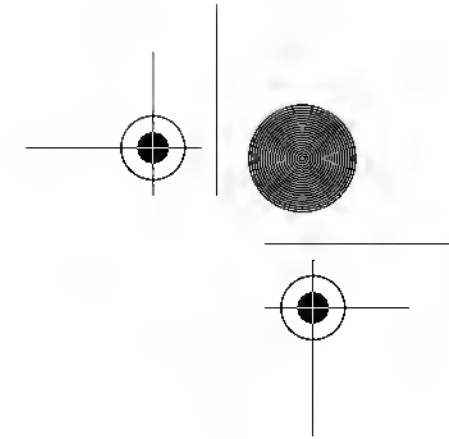
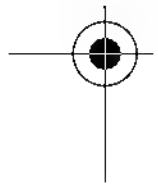
To conclude, the present example illustrates how microbial growth on itself may cause a dynamic change of the environmental conditions, e.g., by the production of metabolites.

### 7.5 CONCLUSIONS

Dynamic mathematical models allow for a consistent computation of the impact of different steps associated with the production, distribution, and retailing of a food (characterized by time-varying conditions) on microbial dynamics. Moreover, the intrinsic properties of microbial evolution such as growth-related product formation and inhibition can be easily integrated and predicted.

Examples given in this paper illustrate how we can *learn* from predictive modeling based on biological and physical ideas. The individual-based modeling approach, for instance, serves as an excellent tool to test generic cell mechanisms with respect to the observed population behavior. However, such a modeling approach with an increased level of detail demands more advanced measurements at the cell or population level or both.





In view of expanding the applicability of predictive models, researchers must be encouraged to aim at an increased *generality* — and thus *transferability* — of model structures. For example, the complete model structure established in Section 7.4 can describe the individual behavior of lactic acid bacteria as well as the inhibitory mechanism in the presence of pathogenic or spoilage bacteria. This example also illustrates that cell density measurements are not always sufficient to establish complex model structures. Components interfering with the microbial dynamics, such as metabolite formation, should be identified, measured, and built into the model structure. Given this increased (experimental) knowledge on the microbial dynamics, we can aim at more *robust* mechanistically inspired models yielding a high predictive quality.

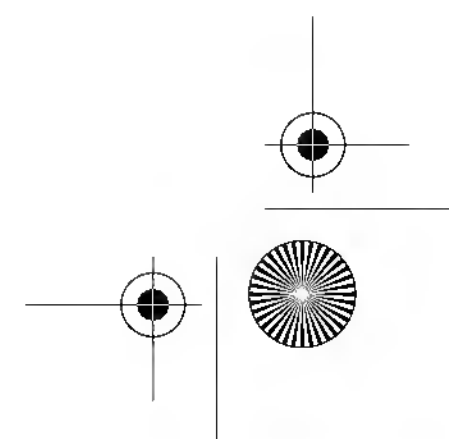
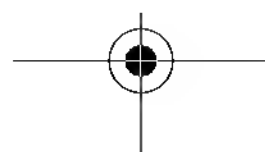
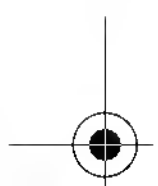
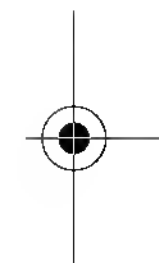
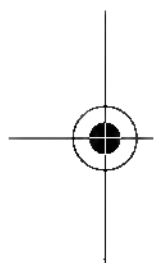
In this respect, it ought to be stressed that model builders can learn (more) from *dynamic experimental data*. Microbial dynamics under realistically time-varying conditions are not necessarily observable from (commonly available) static data. In the first example (see Section 7.3), the application of time-varying temperature profiles revealed the induction of an intermediate lag phase during the exponential growth of *E. coli*.

When extrapolating model structures established on static experimental data to more realistic dynamic conditions, e.g., combination of processing steps, model predictions may fail to describe the microbial evolution accurately. Stephens et al.,<sup>51</sup> for example, observed that slow heating rates applied during inactivation of *Listeria monocytogenes* induced thermotolerance. Predictions using an inactivation model developed on static experiments (not taking into account the magnitude of heating rate) systematically overestimate the effect of the applied heat treatment. Future research should thus pay attention to dynamic model development using dynamic experimental data. In such cases only, complementary effects of dynamic conditions or subsequent treatments can be properly incorporated within the model structure. Observe that synergetic effects form the basic principles within the hurdle technology (see, e.g., Reference 52), which is often addressed in the food industry.

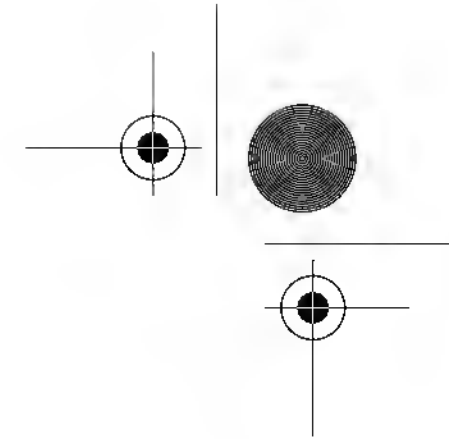
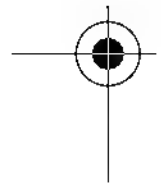
Overall, model improvement aims at an increased predictive accuracy. However, striving for this increased modeling accuracy, one must always keep an eye on the model structure *complexity*. In this respect, it must always be clearly specified for which purpose the model is being developed. An important challenge for the future is therefore the search for a satisfactory trade-off between predictive power and manageability of mathematical models: *When is simple good enough?* (after Reference 53).

## ACKNOWLEDGMENTS

This research was supported by the Research Council of the Katholieke Universiteit Leuven, the Fund for Scientific Research – Flanders (FWO), the European Commission, the Belgian Program on Interuniversity Poles of Attraction, and the Second Multi-Annual Scientific Support Plan for a Sustainable Development Policy, initiated by the Belgian State, Prime Minister's Office for Science, Technology and Culture.

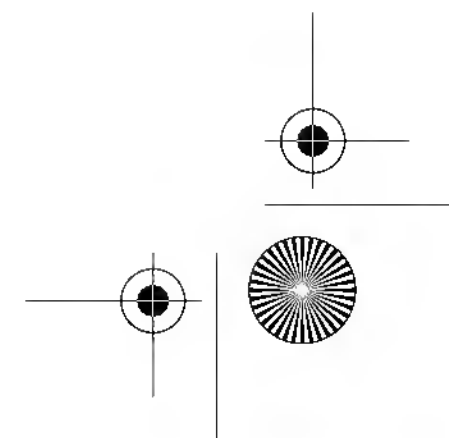
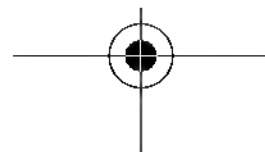
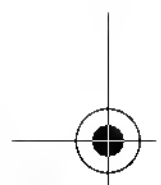
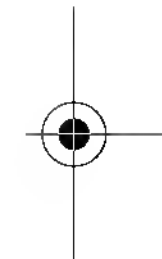
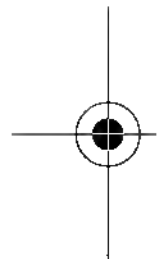


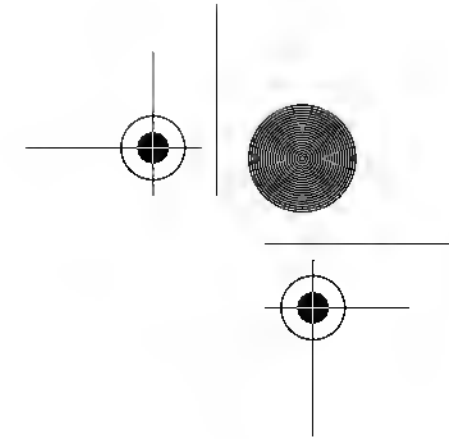
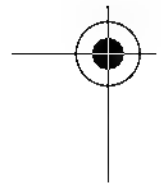




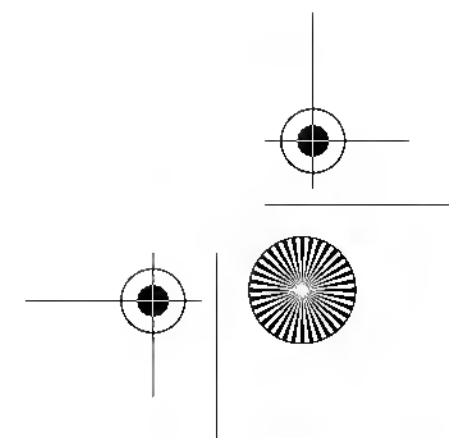
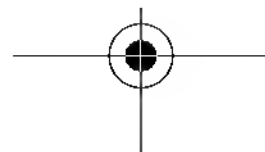
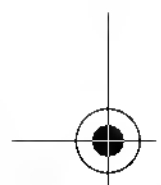
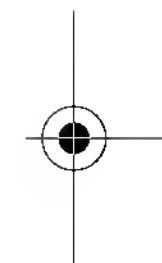
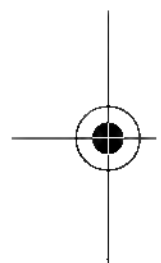
## REFERENCES

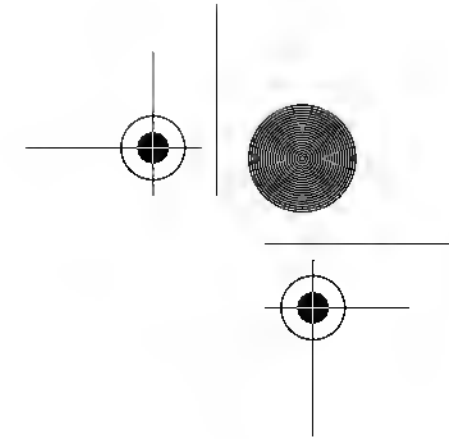
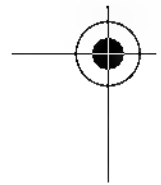
1. Ross, T., McMeekin, T.A., and Baranyi, J., Predictive microbiology and food safety, in *Encyclopedia of Food Microbiology*, Volume 3, Robinson, R.K., Batt, C.A., and Patel, P.D., Eds., Academic Press, San Diego, 2000, p. 1699.
2. Cassin, M.H., Lammerding, A.M., Todd, E.C.D., Ross, W., and McColl, R.S., Quantitative risk assessment for *Escherichia coli* O157:H7 in ground beef hamburgers, *Int. J. Food Microbiol.*, 4, 21, 1998.
3. Coleman, M.E. and Marks, H.M., Qualitative and quantitative risk assessment, *Food Control*, 10, 289, 1999.
4. Whiting, R.C. and Buchanan, R.L., Microbial modeling, *Food Technol.*, 48(6), 113, 1994.
5. Dalgaard, P., Buch, P., and Silberg, S., Seafood spoilage predictor — development and distribution of a product-specific application software, *Int. J. Food Microbiol.*, 73, 343, 2002.
6. Zwietering, M.H., Jongenburger, I., Rombouts, F.M., and van't Riet, K., Modeling of the bacterial growth curve, *Appl. Environ. Microbiol.*, 56(6), 1875, 1990.
7. Anonymous, Kinetics of microbial inactivation for alternative food processing techniques, *J. Food Sci.*, 4(Suppl.), 108, 2000.
8. Baranyi, J., Roberts, T.A., and McClure, P., A non-autonomous differential equation to model bacterial growth, *Food Microbiol.*, 10, 43, 1993.
9. Van Impe, J.F., Nicolai, B.M., Martens, T., De Baerdemaker, J., and Vandewalle, J., Dynamic mathematical model to predict microbial growth and inactivation during food processing, *Appl. Environ. Microbiol.*, 58(9), 2901, 1992.
10. McMeekin, T.A., Brown, J., Krist, K., Miles, D., Neumeyer, K., Nichols, D.S., Olley, J., Presser, K., Ratkowsky, D.A., Ross, T., Salter, M., and Soontranon, S., Quantitative microbiology: a basis for food safety, *Emerg. Infect. Dis.*, 3(4), 541, 1997.
11. Vereecken, K., Geeraerd, A., Bernaerts, K., Dens, E., Poschet, F., and Van Impe, J., Predicting microbial evolution in foods: general aspects of modelling approaches and practical implementation, *Journal A, Special issue on modelling and control in bioprocesses*, 41(3), 45, 2002.
12. Grimson, M.J. and Barker, G.C., A continuum model for growth of bacterial colonies on a surface, *J. Phys. A Math. Gen.*, 26, 5645, 1993.
13. Zwietering, M.H., de Koos, J.T., Hasenack, B.E., de Wit, J.C., and van't Riet, K., Modeling bacterial growth as a function of temperature, *Appl. Environ. Microbiol.*, 57, 1091, 1991.
14. Baranyi, J. and Roberts, T.A., A dynamic approach to predicting bacterial growth in food, *Int. J. Food Microbiol.*, 23, 277, 1994.
15. Hills, B.P. and Mackey, B.M., Multi-compartment kinetic models for injury, resuscitation, induced lag and growth in bacterial cell populations, *Food Microbiol.*, 12, 333, 1995.
16. Hills, B.P. and Wright, K.M., A new model for bacterial growth in heterogeneous systems, *J. Theor. Biol.*, 168, 31, 1994.
17. McKellar, R.C., Development of a dynamic continuous–discrete–continuous model describing the lag phase of individual bacterial cells, *J. Appl. Microbiol.*, 90, 407, 2001.
18. Van Impe, J.F., Nicolai, B.M., Schellekens, M., Martens, T., and De Baerdemaeker, J., Predictive microbiology in a dynamic environment: a system theory approach, *Int. J. Food Microbiol.*, 25, 227, 1995.





19. Bernaerts, K., Servaes, R.D., Kooyman, S., Versyck, K.J., and Van Impe, J.F., Optimal temperature input design for estimation of the square root model parameters: parameter accuracy and model validity restrictions, *Int. J. Food Microbiol.*, 73(2/3), 145, 2002.
20. Bailey, J.E. and Ollis, D.F., *Biochemical Engineering Fundamentals*, 2nd ed., McGraw-Hill, New York, 1986.
21. Adams, M.R. and Moss, M.O., *Food Microbiology*, Royal Society of Chemistry, Cambridge, UK, 1995.
22. Cerf, O., A review: tailing of survival curves of bacterial spores, *J. Appl. Bacteriol.*, 42(1), 1, 1977.
23. Moats, W.A., Dabbah, R., and Edwards, V.M., Interpretation of nonlogarithmic survivor curves of heated bacteria, *J. Food Sci.*, 36, 523, 1971.
24. Mossel, D.A.A., Corry, J.E.L., Struijk, C.B., and Baird, R.M., *Essentials of the Microbiology of Foods: A Textbook for Advanced Studies*, Wiley, Chichester, UK, 1995.
25. Geeraerd, A.H., Herremans, C.H., and Van Impe, J.F., Structural model requirements to describe microbial inactivation during mild heat treatment, *Int. J. Food Microbiol.*, 59, 185, 2000.
26. Shadbolt, C.T., Ross, T., and McMeekin, T.A., Nonthermal death of *Escherichia coli*, *Int. J. Food Microbiol.*, 49, 129, 1999.
27. Whiting, R.C., Modeling bacterial survival in unfavorable environments, *J. Ind. Microbiol.*, 12, 240, 1993.
28. Shadbolt, C.T., Ross, T., and McMeekin, T.A., Differentiation of the effects of lethal pH and water activity: food safety implications, *Lett. Appl. Microbiol.*, 32, 99, 2001.
29. Zwietering, M.H., de Wit, J.C., Cuppers, H.G.A.M., and van't Riet, K., Modeling of bacterial growth with shifts in temperature, *Appl. Environ. Microbiol.*, 60(1), 204, 1994.
30. Hudson, J.A., Effect of pre-incubation temperature on the lag time of *Aeromonas hydrophila*, *Lett. Appl. Microbiol.*, 16, 274, 1993.
31. Whiting, R.C. and Bagi, L.K., Modeling the lag phase of *Listeria monocytogenes*, *Int. J. Food Microbiol.*, 73(2/3), 291, 2002.
32. Alavi, S.H., Puri, V.M., Knabel, S.J., Mohtar, R.H., and Whiting, R.C., Development and validation of a dynamic growth model for *Listeria monocytogenes* in fluid whole milk. *J. Food Prot.*, 62(2), 170, 1999.
33. Dens, E.J., *Predictive Microbiology of Complex Bacterial/Food Systems: Analysis of New Modelling Approaches*, Department of Food and Microbial Technology, Katholieke Universiteit Leuven, Belgium, No. 166, 2001. Promoters: Prof. J.F. Van Impe and Prof. B Nicolai.
34. Kreft, J.U., Booth, G., and Wimpenny, J.W.T., Bacsim, a simulator for individual-based modelling of bacterial colony growth, *Microbiology*, 144, 3275, 1998.
35. Bermudez, J., Lopez, D., Valls, J., and Wagensberg, J., On the analysis of microbiological processes by Monte Carlo simulation techniques, *Comput. Appl. Biosci.*, 5(4), 305, 1989.
36. Nicolai, B.M. and Van Impe, J.F., Predictive food microbiology: a probabilistic approach, *Math. Comp. Simul.*, 42(2/3), 287, 1996.
37. Cooper, S. and Helmstetter, C.E., Chromosome replication and the division cycle of *Escherichia coli* b/r, *J. Mol. Biol.*, 31, 519, 1968.
38. Donachie, W.D., Relationship between cell size and time of initiation of DNA replication, *Nature*, 219, 1077, 1968.
39. Cooper, S., *Bacterial Growth and Division*, Academic Press, San Diego, CA, 1991.





40. Trueba, F.J., van Spronsen, E.A., Traas, J., and Woldringh, C.L., Effects of temperature on the size and shape of *Escherichia coli* cells, *Arch. Microbiol.*, 131, 235, 1982.
41. Ng, H., Ingraham, J.L., and Marr, A., Damage and derepression in *Escherichia coli* resulting from growth at low temperatures, *J. Bacteriol.*, 84, 331, 1962.
42. Ratkowsky, D.A., Olley, J., McMeekin, T.A., and Ball, A., Relationship between temperature and growth rate of bacterial cultures, *J. Bacteriol.*, 149, 1, 1982.
43. Ljung, L., *System Identification: Theory for the User*, 2nd Ed., Prentice-Hall, Upper Saddle River, NJ, 1999.
44. Davies, K.W., Design of experiments for predictive microbial modeling, *J. Ind. Microbiol.*, 12, 296, 1993.
45. Poschet, F., Geeraerd, A.H., Versyck, K.J., Van Loey, A.M., Ly Nguyen, B., Hendrickx, M.E., and Van Impe, J.F., Comparison of Monte Carlo analysis and linear regression techniques: application to enzyme inactivation, in *Proceedings of the Seventh European Conference Food-Industry and Statistics*, Duby, C. and Cassar, J.Ph., Eds., Agro-industrie et méthodes statistiques, Lille, France, 2002, p. 43.
46. Vereecken, K., Antwi, M., Janssen, M., Holvoet, A., Devlieghere, F., Debevere, J., and Van Impe, J.F., Biocontrol of microbial pathogens with lactic acid bacteria: evaluation through predictive modelling, in *Proceedings and Abstracts of the 18th Symposium of the International Committee on Food Microbiology and Hygiene (ICFMH)*, Axelsson, L., Tronrud, E.S., and Merok, K.J., Eds., MATFORSK, Norwegian Food Research Institute, Oslo, 2002, p. 163.
47. Vereecken, K.M., Devlieghere, F., Bockstaele, A., Debevere, J., and Van Impe, J.F., A model for lactic acid induced inhibition of *Yersinia enterocolitica* in mono- and coculture with *Lactobacillus sakei*, *Food Microbiol.*, 20, 701–713, 2003.
48. Vereecken, K.M. and Van Impe, J.F., Analysis and practical implementation of a model for combined growth and metabolite production of lactic acid bacteria, *Int. J. Food Microbiol.*, 73(2/3), 239, 2002.
49. Wilson, P.D.G., Wilson, D.R., Waspe, C., Hibberd, D., and Brocklehurst, T.F., Application of buffering theory to food microbiology, in *Predictive Modelling in Foods — Conference Proceedings*, Van Impe, J.F. and Bernaerts, K., Eds., KULeuven/BioTeC, Belgium, 2000, p. 52.
50. Breidt, F. and Fleming, H.P., Modeling of the competitive growth of *Listeria monocytogenes* and *Lactococcus lactis* in vegetable broth, *Appl. Environ. Microbiol.*, 64(9), 3159, 1998.
51. Stephens, P.J., Cole, M.B., and Jones, M.V., Effect of heating rate on the thermal inactivation of *Listeria monocytogenes*, *J. Appl. Bacteriol.*, 77, 702, 1994.
52. Leistner, L., *Principles and Applications of Hurdle Technology*, Blackie Academic and Professional, Bedford, TX, 1995.
53. Buchanan, R.L., Whiting, R.C., and Damert, W.C., When is simple good enough: a comparison of the Gompertz, Baranyi and three-phase linear models for fitting bacterial growth curves, *Food Microbiol.*, 14, 313, 1997.

